

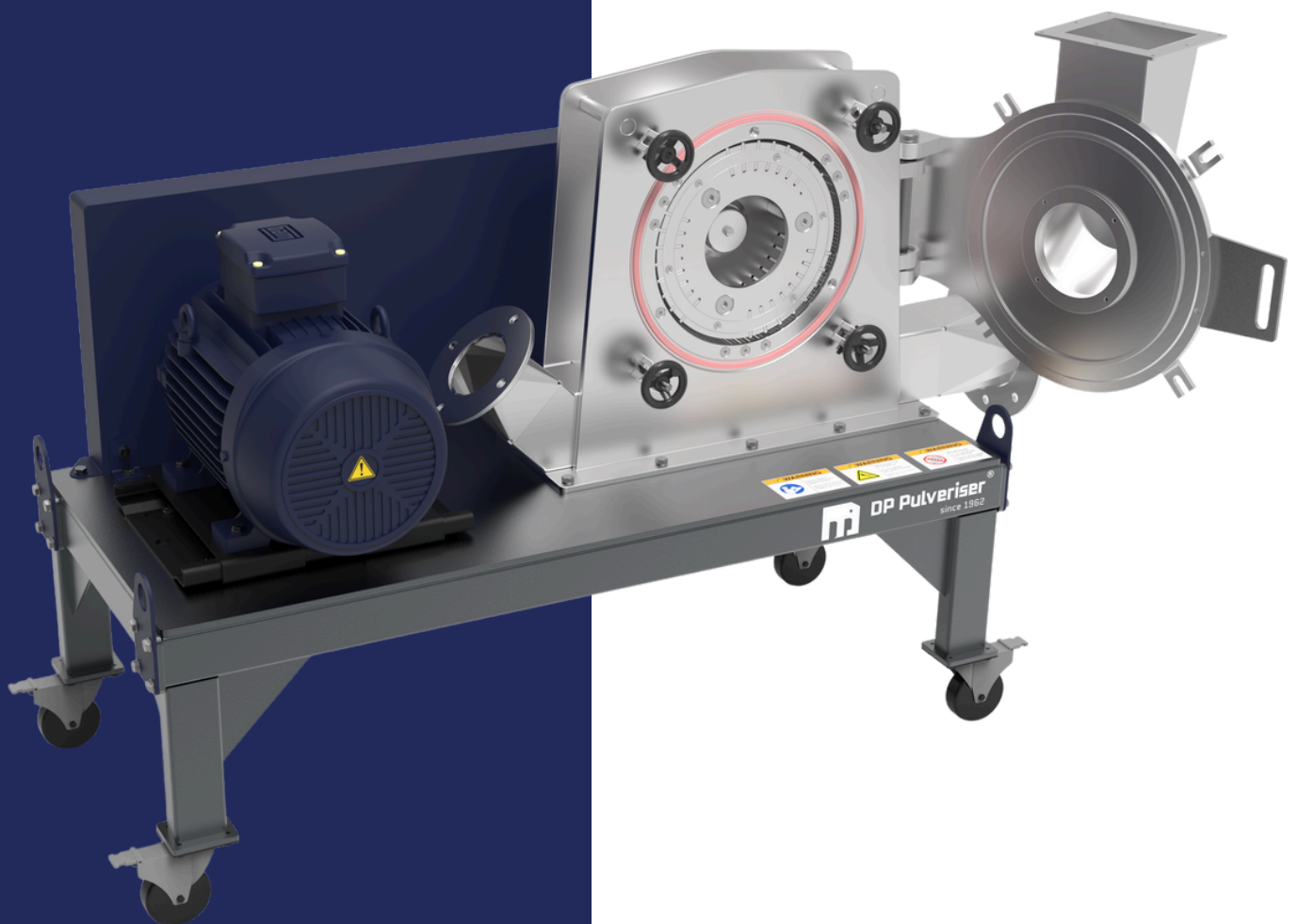

**DP Pulveriser**<sup>®</sup>  
since 1962



## **DP® UNIVA Series Bar Turbo Mill**

*Universal Mill*

## Introduction

The DP® Bar Turbo Mill is a high-speed impact mill with a bar turbo rotor, equipped with a screen and liner for precise output size. Designed for medium to fine grinding of brittle to tough-elastic materials, it ensures consistent performance and easy cleaning for food, chemical, and pharmaceutical applications.

- 1 Feed Hopper With Vibratory Feeder
- 2 DP® Bar Turbo Mill
- 3 Material Discharge
- 4 Rotary Air Valve
- 5 Dust Collector
- 6 Blower
- 7 Control Panel
- 8 PLC Panel

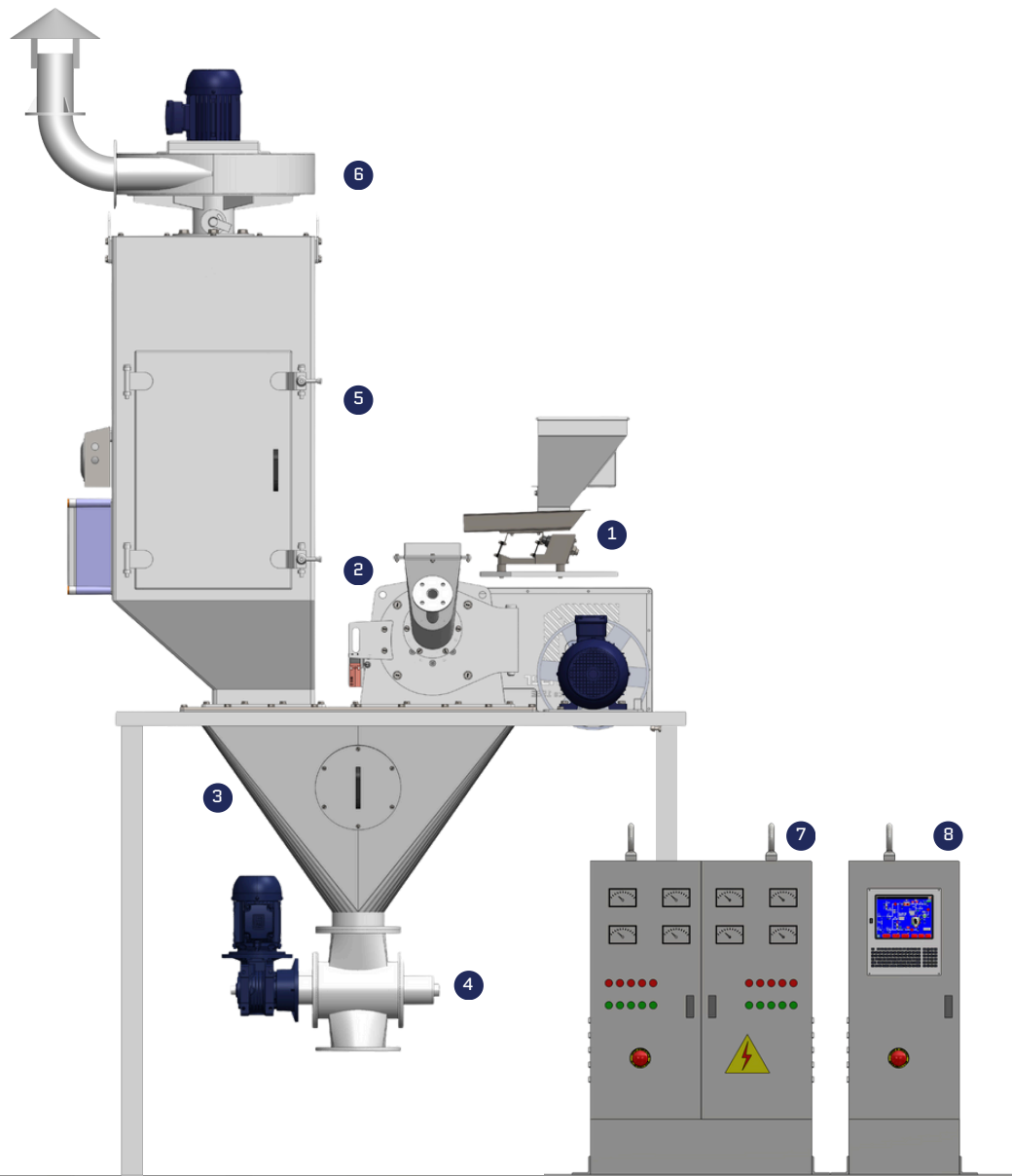

► Typical process flow diagram of a standard Bar Turbo Mill

## Working Principle

The DP® Bar Turbo Mill operates on the principle of high-speed impact and shearing between rotor-mounted bars and a fixed liner. Material enters through the **feed inlet (1)** and is directed into the **grinding zone (2)** by gravity or controlled feeding systems such as a screw or vibratory feeder. Air can be introduced via the **air inlet (6)** to assist in material transport, cooling, and fluidization during milling.

Inside the grinding chamber, the **bar turbo rotor (3)** is fitted with multiple **bars (5)** that accelerate particles toward the **liner and screen (4)**. The material is first broken down on impact with the bars, then further reduced by repeated contact and compression between the rotating bars and the fixed liner. The screen ensures only particles of the desired size pass through.

This system is suitable for brittle to tough-elastic materials, delivering precise and consistent output. The final product, along with process air, exits via the **fine product & air outlet (7)** for gravity discharge collection or pneumatic conveying. Particle size can be controlled by selecting the appropriate screen opening, rotor speed, and feed rate to suit specific application requirements.

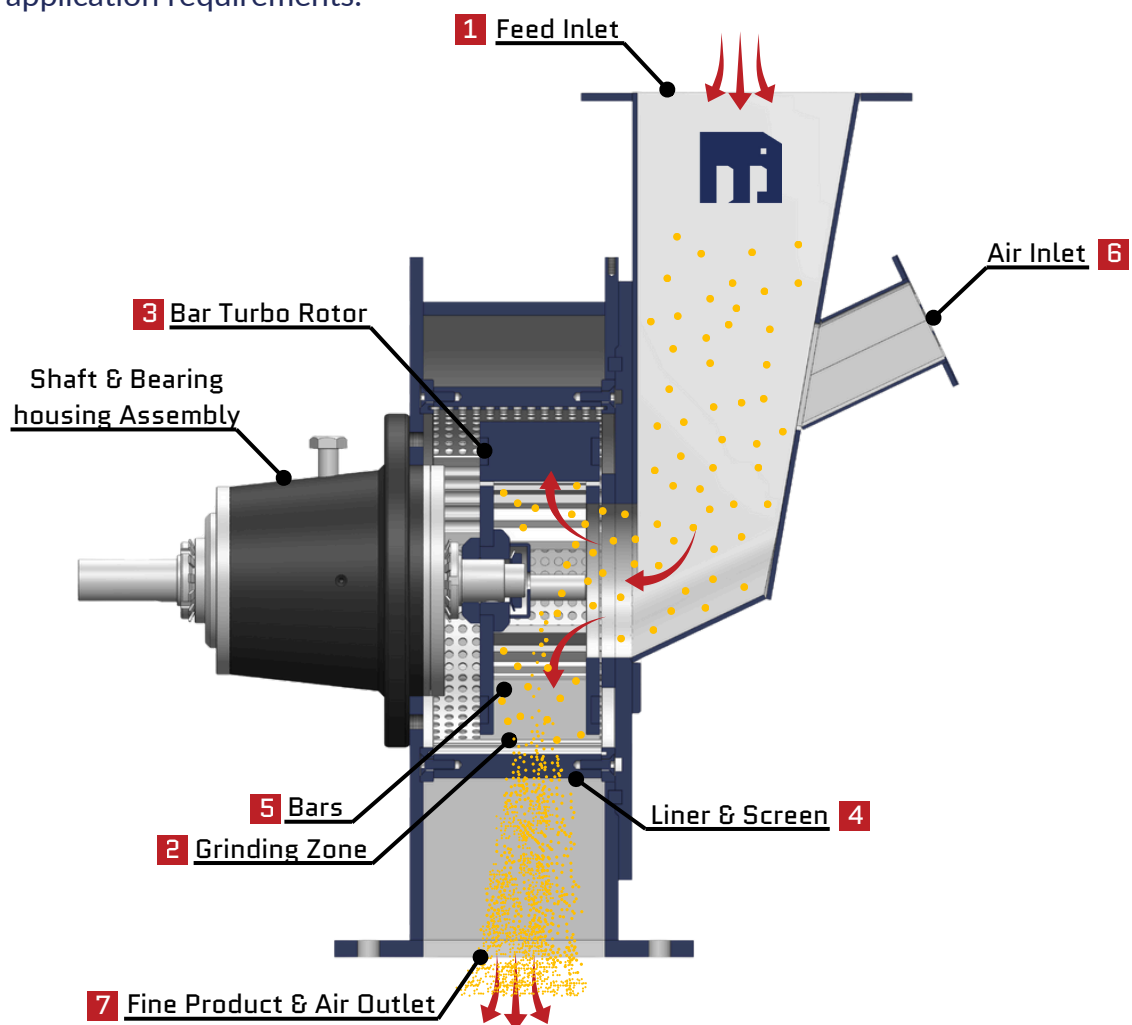

► A cross-sectional view of the Bar Turbo Mill

## Features & Benefits

- ▶ Interchangeable bar blades allow use of both edges, extending service life and reducing maintenance costs.
- ▶ Due to fan type rotor design, higher airflow is produced which means cooler operation and protection of heat-sensitive materials.
- ▶ Variable speed rotor drive for precise control of fineness and throughput.
- ▶ Operates efficiently with low energy consumption and reduced operating costs.



▶ Gravity bunker discharge arrangement



▶ Pneumatic conveying discharge arrangement

- ▶ Uniform output size ensured by close-tolerance grinding zone and screen assembly.
- ▶ Consistent performance with screen and liner design ensuring uniform output.
- ▶ Grinding chamber and components designed for easy access and quick cleaning.

## Options and Accessories

- ▶ **Explosion Protection:** Available with pressure shock-resistant construction to meet dust explosion safety standards, supporting overpressure resistance up to 10 bar.
- ▶ **Metal Separation:** Can be equipped with inline magnetic separators or metal detectors to ensure product purity and safeguard downstream equipment.
- ▶ **Screen Variants:** Wide range of screen sizes and patterns to precisely control particle size distribution for different applications.
- ▶ **Feeding & Discharge Systems:** Compatible with screw feeders, vibratory feeders, gravity feed hoppers, pneumatic conveying, and gravity discharge arrangements.
- ▶ **Instrumentation & Monitoring:** Can be equipped with temperature probes, vibration sensors, and safety interlocks for process control and equipment protection.
- ▶ **Variable Speed Drive:** Frequency-controlled motor drive for accurate adjustment of rotor speed and particle size.



- ▶ DP® UNV-320BT-EX in Explosion Resistant design upto PSR 11 bar

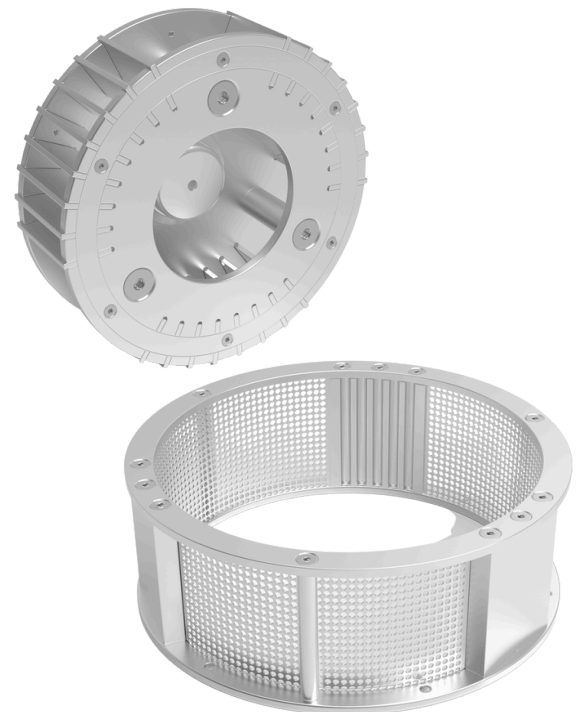

- ▶ Bar Turbo and Screen & Liner assembly

## Machine size

Model	Rotor drive	Mill speed [Max.]	Max. air flow rate	Scale-up factor
UNV	kW	rpm	m <sup>3</sup> /h	-
105	1.5	15000	-	0.06
180	5.5	12000	-	0.25
255	11	8300	1050	0.5
320	18.5	7100	1500	1
510	37	4500	3200	2
640	75	3500	5200	3.6
805	90	2800	7500	4.5
1020	110	2400	10000	6.3
1280	250	1850	12500	9



▶ DP® UNV-255BT UNIVA Series Bar Turbo Mill System



▶ DP® UNV-320BT Bar Turbo Mill ready for dispatch



▶ Internal view of grinding chamber in a DP® UNV-320BT



▶ DP® UNV-255BT Bar Turbo Mill ready for dispatch



▶ DP® UNV-320BT Bar Turbo Mill ready for dispatch



▶ DP® UNV-255BT Bar Turbo Mill ready for dispatch



▶ Installation of DP® UNV-255BT Bar Turbo Mill in Africa



▶ DP® UNV-320BT Bar Turbo Mill pneumatic conveying type ready for dispatch



▶ Typical control panel of schematic of our UNIVA series mills



▶ Installation of DP® UNV-255BT Bar Turbo Mill for sugar grinding



▶ DP® UNV-255BT Bar Turbo Mill ready for dispatch



▶ DP® UNV-255BT Bar Turbo Mill ready for dispatch



▶ DP® UNV-320BT Bar Turbo Mill ready for dispatch

## Who are WE?

We are DP Pulveriser Industries and have been designing and building size reduction equipment in India since 1962. We believe in using the materials of the highest grade to build our equipment because we understand your need for a machine that will perform - without breakdown - day in and day out. 60+ years, 7500 installations and 32 countries later we now hold the reputation of being one of India's finest manufacturers of size reduction equipment. Regardless of the industry you operate in, DP can optimize, innovate and automate your entire process with tailor made solutions and expertise that is backed by 60+ years of experience. We are a young bunch of passionate engineers excited to work on your next challenging project



## What do we DO?

DP Pulveriser Industries' offerings are broadly classified under 3 segments:



### Powder Processing Equipment

Built for durability and low maintenance even after years of service, Our core strength lies in Size Reduction and Air Classification. We offer a wide range of machines to meet all your particle size requirements.

### Testing and Other Services

We offer various services such as material trials of our equipment, grinding and air classification of your material on a contract basis and even particle testing and analysis at a fully equipped laboratory on the campus of our partner IIT Gandhinagar.

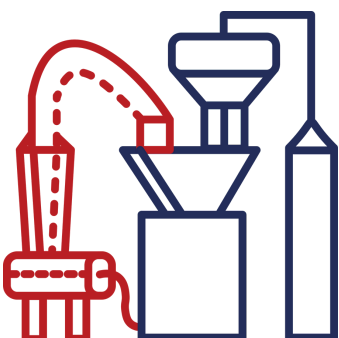

### Turnkey Systems & Plant Automation

Thanks to our decades of experience, we understand what processing technologies and equipment are best suited for your application and industry. This means we can be your one stop solution for setting up complete powder processing plants carefully tailored to your needs.



## Our Global Footprint

Australia Bahrain Bangladesh Bhutan Canada China Estonia  
Bremen Ghana Hongkong Iran Indonesia Kenya Mauritius  
Mexico Malaysia Newzealand Nepal Nigeria Oman Philippines  
Saudi Arabia South Africa Singapore Sri Lanka Tanzania  
Qatar U.A.E Guatemala Zambia Uruguay



[www.dppulveriser.com](http://www.dppulveriser.com)

[www.dpmills.com](http://www.dpmills.com)

